

# **CANTRELL**

## **WORLDWIDE INC.**

2154 CHENAULT DRIVE • BUILDING A • CARROLLTON • TEXAS • 75006  
PHONE: 972-302-2557 • FAX: 214-279-0855  
WWW.CANTRELLWORLDWIDE.COM

**NEW...**

## **176 & 200 SAW FILER**

The performance of your lint room is critical to maintaining quality lint at the highest capacity obtainable. Nothing controls your lint quality and capacity as a good sharp saw tooth, and nothing controls a good sharp saw tooth as your precision saw filer. So it stands to reason that you want the best saw filer obtainable for your operation. Well here it is!

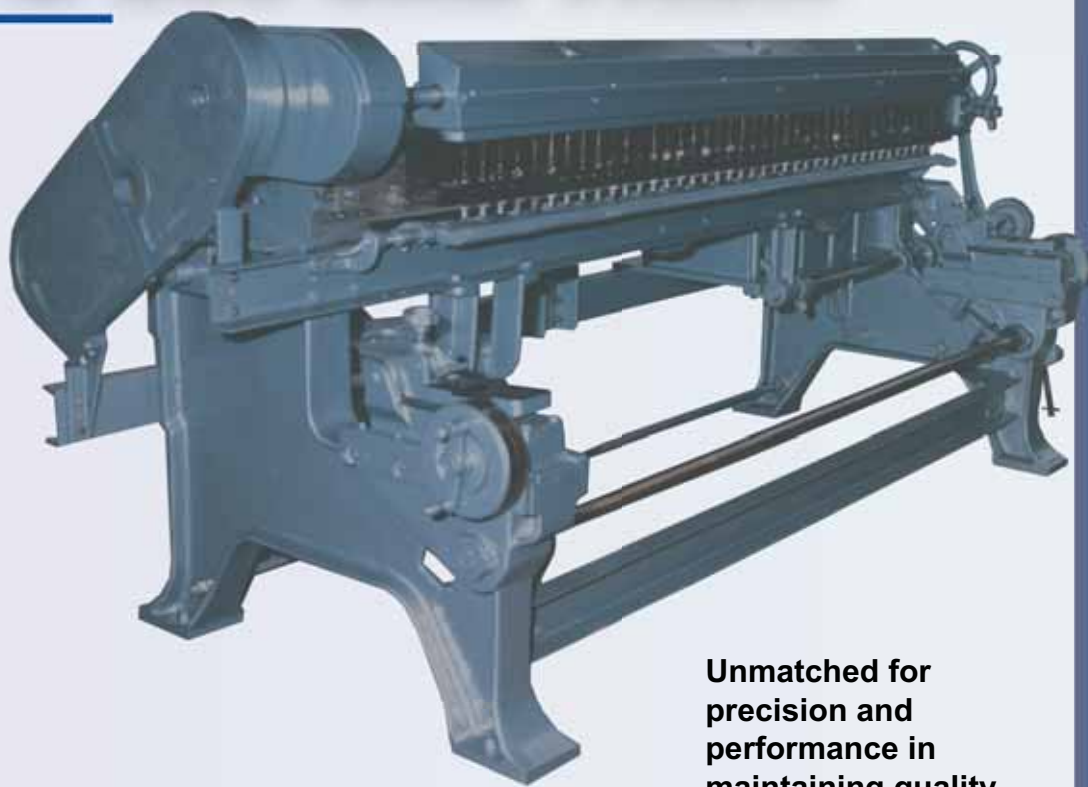

Unmatched for precision and performance in maintaining quality uniform teeth, throughout the life of your saws.

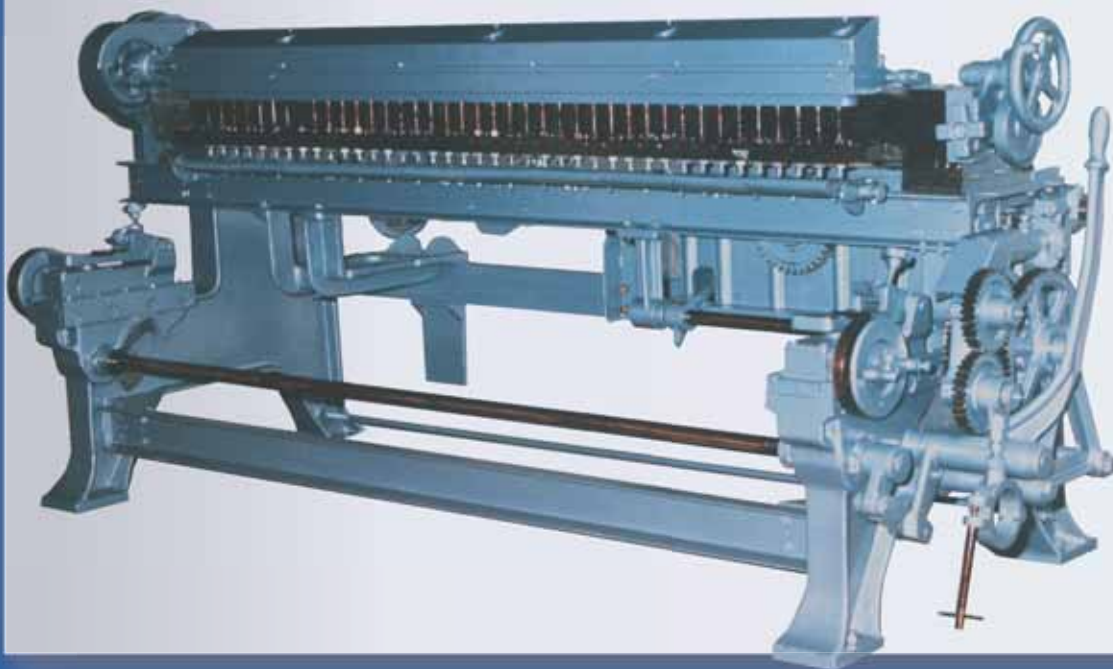

Completely automatic saw filer with machine tool accuracy.

Ruggedly built for smooth operation and reliability.

Completely interchangeable parts for low maintenance and service ease.

# SPECIFICATIONS: 176 & 200 SAW FILER

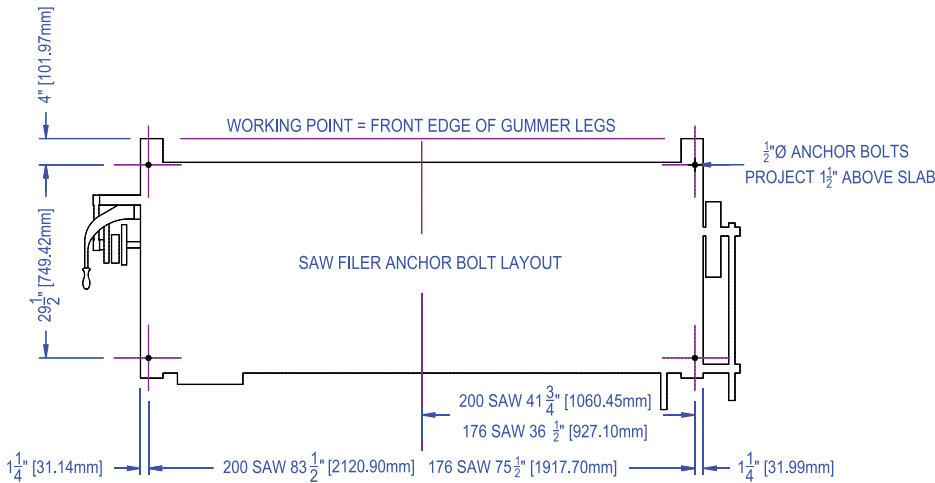

THE CANTRELL 176 & 200 SAW FILER MAINTAINES SAWS IN PERFECT CONDITION AT ALL TIMES. THE CANTRELL SAW FILER HAS MACHINE TOOL PRECISION THAT WILL CUT IN AND MAINTAIN A GOOD TOOTH PROFILE THROUGHOUT THE LIFE OF THE SAWS.

CANTRELL HAS DEVELOPED MANY IMPROVEMENTS TO THE SAW SHARPENING PROCESS INCLUDING A BRAND NEW "ENGINEERED" SAW FILE.

THE NEW SAW FILE COMBINED WITH THE NEW SAW FILER CREATES AN ENHANCED TOOTH PROFILE THAT PROMOTES HIGHER DELINTING CAPACITIES.

THE SAW FILER IS DESIGNED TO PROVIDE EXTRA LONG LIFE WHILE MAINTAINING QUALITY AND CONSISTENCY NEVER BEFORE ACHIEVED.

## ELEVATION

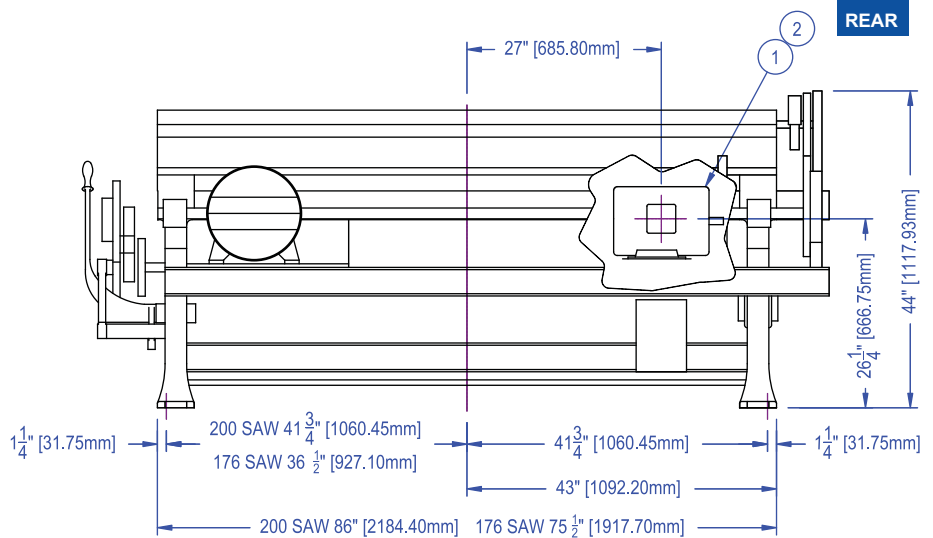
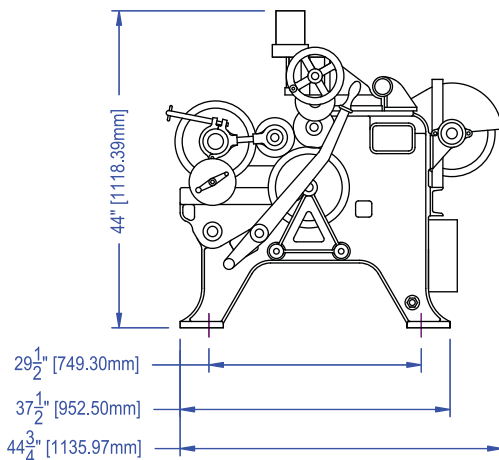

- 1] 176 SAW DRIVE MOTOR - 2 HP - 60 HZ / 3 HP - 50 HZ
- 2] 200 SAW DRIVE MOTOR - 3 HP - 60 HZ / 5 HP - 50 HZ
- 3] SHIPPING WEIGHT: (176) 1930 LBS / 875.4KG (200) 2150 LBS / 975.2KG
- 4] SHIPPING VOLUME: (176) 145 FT<sup>3</sup> / 4.1 M<sup>3</sup> (200) 160 FT<sup>3</sup> / 4.5 M<sup>3</sup>
- 5] CANTRELL PROVIDES A COMPLETE LINE OF PARTS AND ACCESSORIES



**CANTRELL  
WORLDWIDE INC.**

2154 CHENAULT DRIVE ● BUILDING A ● CARROLLTON ● TEXAS ● 75006  
PHONE: 972-302-2557 ● FAX: 214-279-0855

WWW.CANTRELLWORLDWIDE.COM