

CANTRELL

WORLDWIDE INC.

2154 CHENAULT DRIVE ● BUILDING A ● CARROLLTON ● TEXAS ● 75006
PHONE: 972-302-2557 ● FAX: 214-279-0855
WWW.CANTRELLWORLDWIDE.COM

NEW...

48" EIGHT BASKET BEATER

For better fluffing of linty hulls and highest recovery of meats.

Self cleaning screens for more consistent results.

Beater screens mounted in easy-pull trays for quick change and ease of maintenance.

Extra heavy duty eccentrics for long life.

Clean rugged design with steel plate construction.



SPECIFICATIONS: 48" EIGHT BASKET BEATER

PLAN

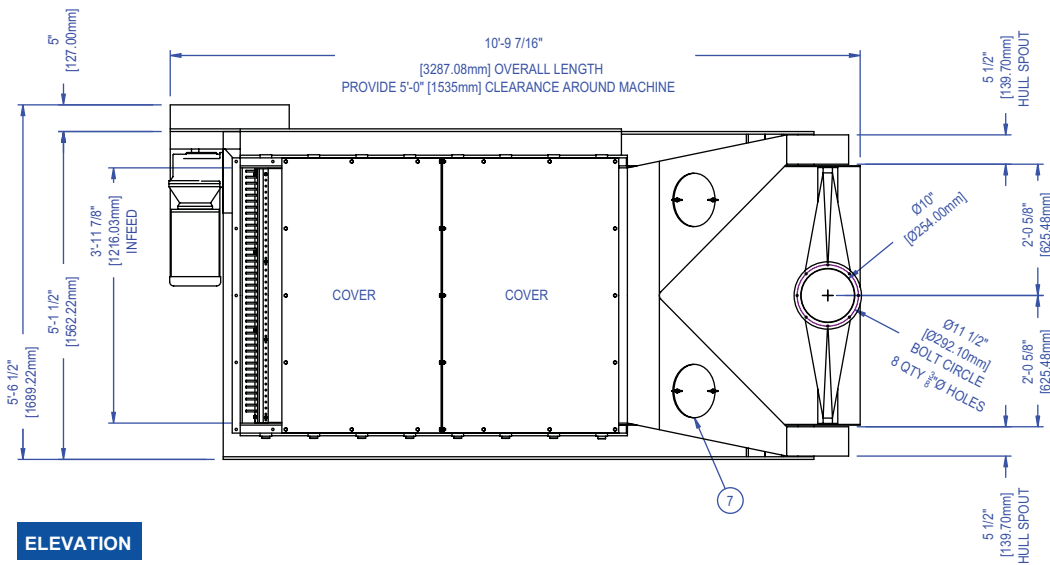

THE CANTRELL BEATER / SHAKER IS DESIGNED TO PRODUCE HULLS WITH A MINIMUM OIL CONTENT BY EFFICIENTLY BEATING THE HULLS TO REMOVE THE FINE, FLOURY AND SMALL PARTICLES OF MEATS AND OILY LINT.

THE MACHINE CONSISTS OF AN EIGHT-CHAMBER BEATER SECTION MOUNTED ABOVE A SHAKER SEPARATOR TRAY.

ELEVATION

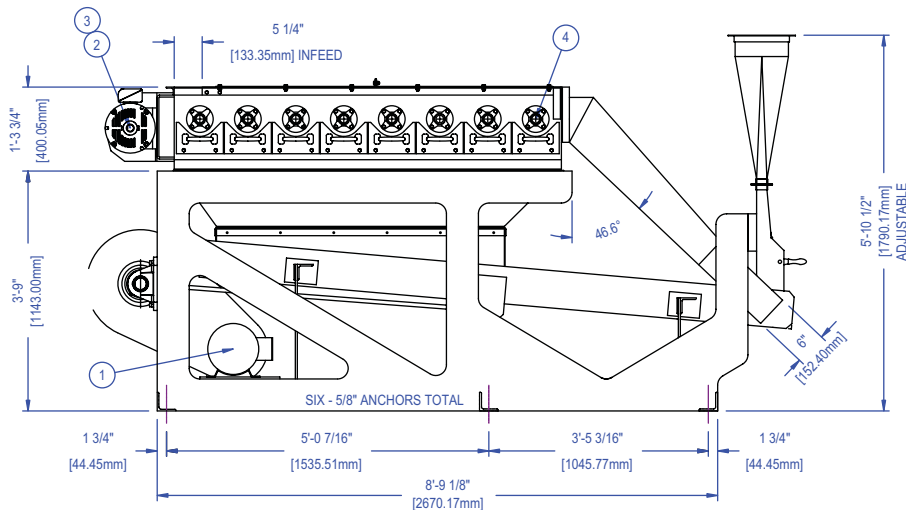

FRONT

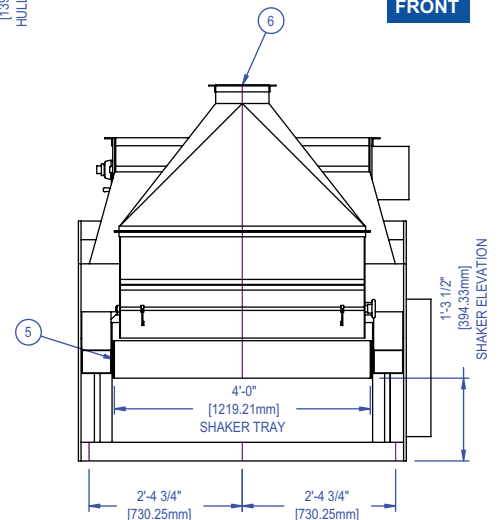

1] SHAKER MOTOR - 2HP - 1000/1200RPM - 380/230-460V / 3PH / 50-60HZ

2] BEATER MOTOR - 3HP - 1450/1750RPM - 380/230-460V / 3PH / 50-60HZ

3] GEAR REDUCER, DOUBLE REDUCTION / HELICAL GEAR 9.3:1

4] 48" EIGHT STATIONARY SCREENS - REMOVABLE

5] SHAKER TRAY - 36 SQ FT OF SELF CLEANING SASH

6] ADJUSTABLE AIR HOOD - 10" DIA. / 1900 CFM / 3484 FPM

7] INSPECTION WINDOWS - 2 LARGE 10" DIA. VIEWING AREAS

8] HEAVY RUGGED \ PLATE CONSTRUCTION

9] SHIPPING WEIGHT: 4500 LBS / 2041 KG

10] SHIPPING VOLUME: 350 FT³ / 10 M³



2154 CHENAULT DRIVE • BUILDING A • CARROLLTON • TEXAS • 75006
PHONE: 972-302-2557 • FAX: 214-279-0855

WWW.CANTRELLWORLDWIDE.COM